

PROFESSIONAL RACING CYCLES 1990



 **PEUGEOT**
CYCLES

Designed for winners

The racing pedigree of Cycles Peugeot is unrivalled. It is a success story that stretches back over many years and countless competition triumphs in the world's leading races.

Joey McLoughlin, Sean Yates and the winner of last year's Kellogg's Tour of Britain, Robert Millar, are just some of the cycle

super stars who have raced away to victory on Peugeot.

The wealth of experience and knowledge gained from this superlative racing record has enabled us to design and develop what we firmly believe is the finest range of ready-to-race professional speed machines ever produced. A tried and tested range that will prove

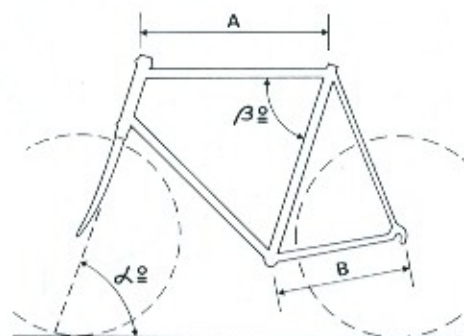

SIZE(cms)	α	β	A(mm)	B(mm)
52	72	76	529	400
54	72	75	538	400
56	72	74.5	548	400
58	73.5	74	570	400
60	73.5	73.5	580	400
62	73.5	73	591	405
64	73.5	72.5	597	405

unbeatable at every competitive level.

At the heart of this magnificent range are the incomparable Peugeot frames, built from the latest Reynolds tubing for super-lightness.

The new geometry and aerodynamics of these innovative frames, designed by advanced technology, take these sleek,



streamlined machines into exciting new dimensions of race winning speed and response.

The list of original equipment is the finest you will find, the top quality components that you would choose if you were creating your own dream racer. Campagnolo, Shimano, Look and Wolber are just a few of the world renowned names.

This is a supreme range of craftsman built, ready-to-race cycles, each available in seven



different sizes, that any top professional would be both pleased and proud to ride.

The Peugeot Professional Racing Range - designed for winners by winners.



PEUGEOT
CYCLES

This is the ultimate ready-to-race professional machine. A dream of a machine that is bursting with competitive performance and speed. The superb Reynolds 753 frame combines ultra lightness with incredible strength and lightning fast response. Equipped with the latest European components, including Campagnolo Chorus groupset, Wolber tubulars, Wolber Profil 20 rims and the new Look PP96 Carbon Pro pedal system which provides additional lateral foot movement, 753 Chorus is destined to become the number one choice of champions.

753 CHORUS

FRAME SIZES: 52cm (20½"), 54cm (21½"), 56cm (22"), 58cm (23"), 60cm (23½"), 62cm (24"), 64cm (25½")

FRAME MATERIAL: REYNOLDS 753 tubing, half-chromed fastback stays, forged chromed vertical dropouts, 2 sets of bottle cage mounts

HEADSET: CAMPAGNOLO CHORUS

FORK: REYNOLDS 753 fork blades, aero crown

RIMS: WOLBER Profil 20, aero anodised, stainless spokes

HUBS: CAMPAGNOLO small flange quick-release, alloy

TUBULARS: WOLBER Champion de France SPI

HANDLEBAR: 3TTT Race Team, alloy engraved, anodised

STEM: 3TTT alloy aero

BRAKES: CAMPAGNOLO Chorus short-reach alloy side-pull, with alloy levers and white gumhoods

GEARS: CAMPAGNOLO Chorus short arm rear mechanism, non-indexed down tube levers

CHAINSET: CAMPAGNOLO Chorus, 42 x 53T chainrings, 170mm cranks

FREEWHEEL: 7-speed, 12 x 18T, silver

PEDALS: New LOOK PP96 Carbo Pro, red (supplied with shoe plates)

SADDLE: ROLLS San Marco

SEAT PIN: CAMPAGNOLO, aero

COLOUR: Two-tone Dark Blue/Light Blue, with PEUGEOT blaze transfers

REF: CRT1008Y



A sleek, streamlined pro racer for the professional rider on his way to the top. Stylish performance features include Reynolds 653 frame and forks, Mavic Mach 2CD rims with Wolber Pro SP1 tyres, Campagnolo Athena groupset and a Turbo Special saddle. In Peugeot Racing Team colours the 653 Athena looks every bit as good as it performs.

653 ATHENA

- FRAME SIZES:** 52cm (20½"), 54cm (21½"), 56 cm (22"), 58cm (23"), 60cm (23½"), 62cm (24"), 64cm (25¼")
- FRAME MATERIAL:** REYNOLDS 653 tubing, half-chromed fastback stays, forged chromed vertical dropouts, 2 sets of bottle cage mounts
- HEADSET:** CAMPAGNOLO Athena
- FORK:** REYNOLDS 653 fork blades, aero crown
- RIMS:** MAVIC MACH 2CD, aero anodised, stainless spokes
- HUBS:** CAMPAGNOLO small flange quick-release, alloy
- TUBULARS:** WOLBER Pro SP1 with polyurethane protection system
- HANDLEBAR:** 3TTT Competition, alloy engraved, anodised
- STEM:** 3TTT alloy anodised, aero
- BRAKES:** CAMPAGNOLO Athena alloy side-pull, with alloy aero levers and white gumhoods
- GEARS:** CAMPAGNOLO Athena, indexed levers
- CHAINSET:** CAMPAGNOLO Athena, 42 x 52T chainrings, 170mm cranks
- FREEWHEEL:** 7-speed, 12 x 21T, silver
- PEDALS:** LOOK PP76 Carbon, violet (supplied with shoe plates)
- SADDLE:** TURBO Special, black
- SEAT PIN:** CAMPAGNOLO, aero
- COLOUR:** Two-tone Violet/Pink, with PEUGEOT blaze transfers
- REF:** CR700BY

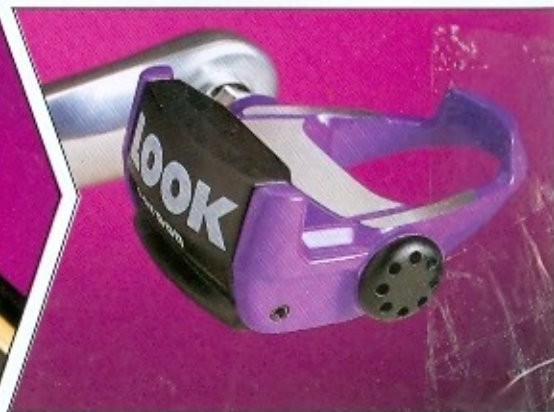

531 ALTUS

Ideal in every way for the top amateur who wants to lift performance levels to even greater heights. This lightweight, responsive machine with Reynolds 531 tubing, Shimano new 105 groupset, Mavic rims and Michelin Hi-Lite tyres is a top competition cycle at a highly competitive price.

- FRAME SIZES:** 52cm (20½"), 54cm (21½"), 56cm (22"), 58cm (23"), 60cm (23½"), 62cm (24"), 64cm (25½")
- FRAME MATERIAL:** REYNOLDS 531 butted tubes, vertical dropouts, 2 sets of bottle cage mounts
- HEADSET:** SHIMANO 105
- FORK:** REYNOLDS 531 fork blades, aero crown
- RIMS:** MAVIC 190 NE black anodised, stainless spokes
- HUBS:** SHIMANO 105, alloy anodised, small flange, quick release
- TYRES:** MICHELIN Hi-Lite Comp
- HANDLEBAR:** PHILIPPE Tour de France, alloy engraved
- STEM:** ATAX ASC, alloy
- BRAKES:** SHIMANO 105, SLR (Shimano linear response) with aero levers and white gumhoods
- GEARS:** SHIMANO 105, front and rear
- CHAINSET:** SHIMANO 105 SG (Superglide), BIOPACE, 42 x 52T chainrings, 170mm cranks
- FREEWHEEL:** 7-speed, 12 x 21T, silver
- PEDALS:** SHIMANO 105 Aero, with toe clips and CHRISTOPHE white leather straps
- SADDLE:** TURBO Gel, black
- SEAT PIN:** Alloy aero
- COLOUR:** Two-tone Violet/Water Green, with PEUGEOT blaze transfers
- REF:** CR500BY



